



Solution for a better weigh

Pallet Scale

NDP550 / NDP685



* Optional Item - Printer

Skilled Creativity, Professional Manufacturing

A. Original and Creative Intelligent Auto-Backlight

The backlight adjusts automatically according to exterior condition; ensuring clear display of visual.

B. Pallet Scales' Specialized Indicator

The large screen indicator is developed specially for pallet scales, which provides both convenience and ease of use. Additionally, the exterior is made with a hard & durable protective case, ensuring minimal damage to the indicator.

C. New Loadcell

The new precision load cells ensure accurate performance of the pallet jack scale.

D. High-Intensities Truck Leg

With structural mechanics in the truck leg, it will result in an increase in strength without any material increase.

E. Leg's Balance Adjustment

The adjustable bolt can adjust two legs' balance quickly. Disassembling for repairs are also been made simple.

F. Foot brake

The brake device greatly improves stability, which will be crucial for everyday use.



Foot Brake

(Optional)

This brake device greatly improves stability, hence weighing and handling the pallet scale will be more secure.



NDP Pallet Scales

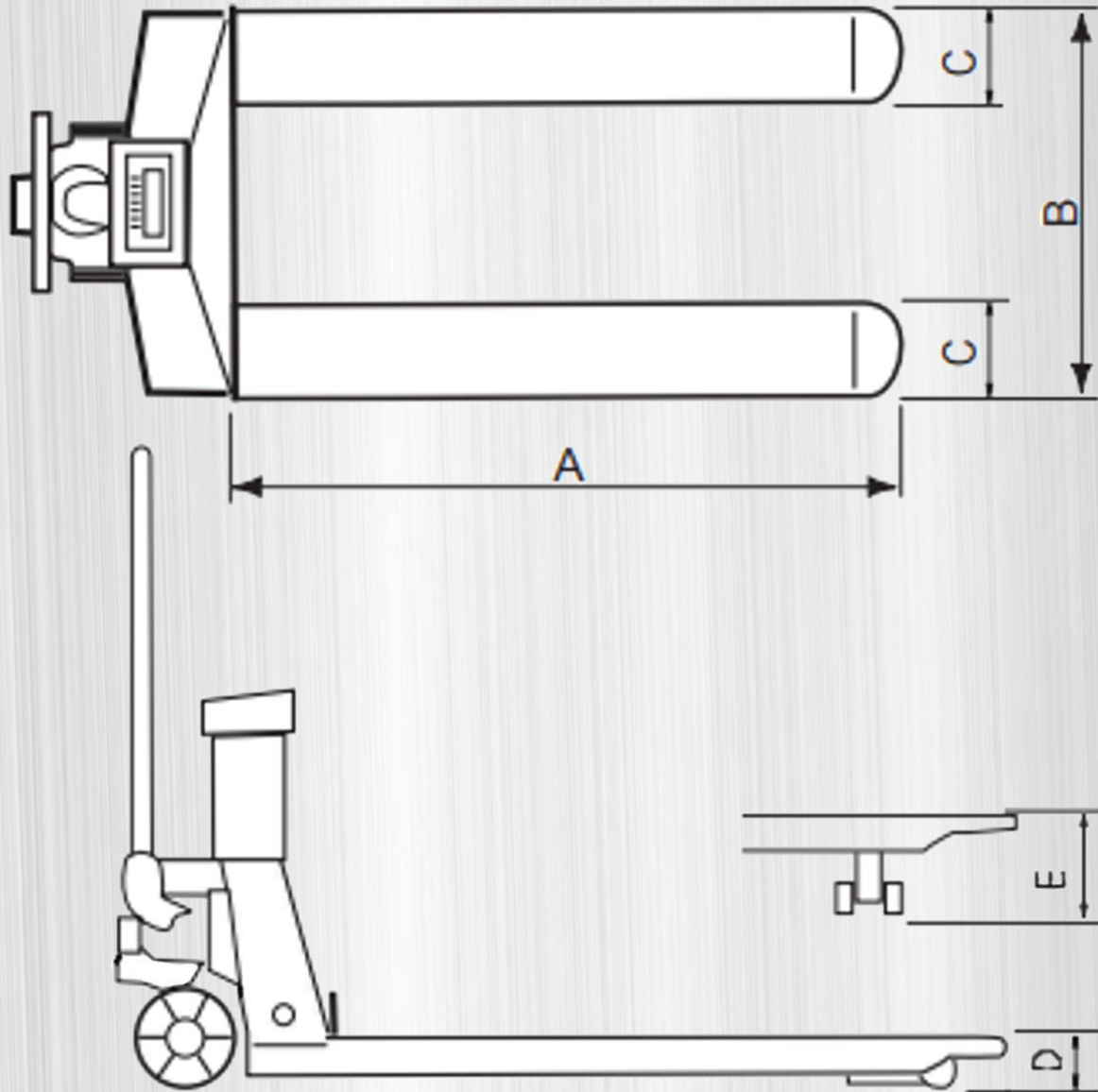

Model	A	B	C	D	E	Capacity
NDP 550	1150mm	550mm	160mm	80mm	195mm	1000kg x 0.2kg 2000kg x 0.5kg
NDP 685	1150mm	685mm	160mm	80mm	195mm	1000kg x 0.2kg 2000kg x 0.5kg

EU & CE * ^ a a | ^ a a c i ^ a a c | ^ a a c o t o e y ^ a ^ a c ~ ! • E & c e * a * ^ a | ^ a a ^ a a [~ } a ^ a c ~ ! •